

CAD FILE : Z:\LM\NEW\R14\SS\SS22K26

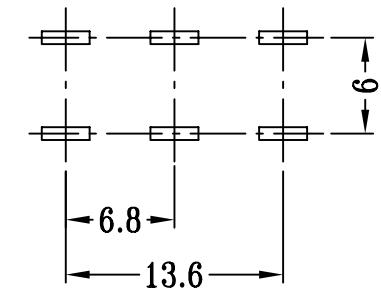
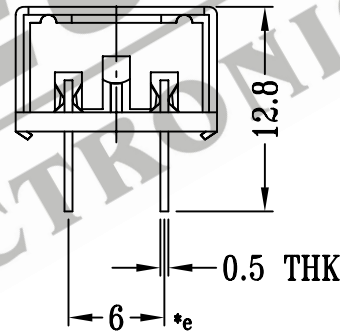
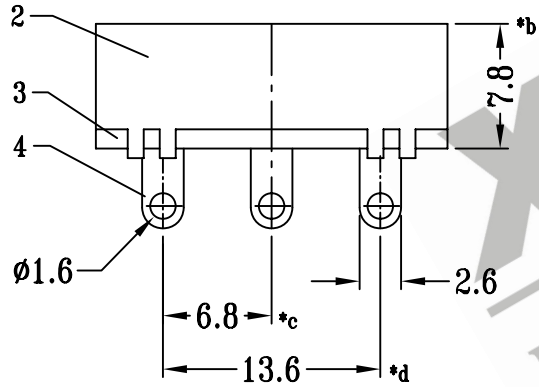
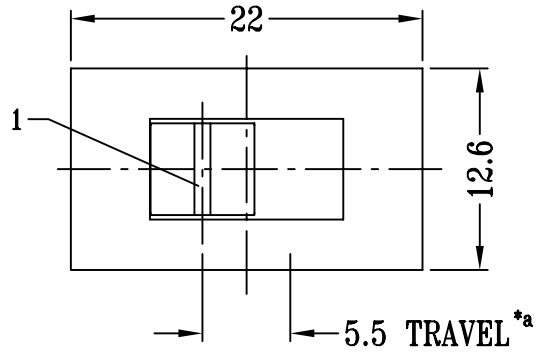

SCHMATIC (NON-SHORTING)

P.C.B LAYOUT

注:带"*"表示关键尺寸(5个)

8	CONTACT CLIP	PBS STRIP	2	Ag PLATED	TOLERANCE UNLESS SPECIFIED	SHENZHEN XIEJIA ELECTRONICS CO.,LTD.				
7	POSITION PLATE	STEEL STRIP	1	Ni PLATED						
6	STEEL BALL	STEEL	1	NATURAL	WITHIN : 1.5±0.1mm OVER : 1.5±0.2mm	ISSUE	DATE	DESCRIPTIONS		APPD
5	SPRING	STEEL WIRE	1	TEMPER		TITLE: VERTICAL SLIDE SWITCH	UNIT : M M	DRWG NO : XJ-DR-SS22K26-00		
4	TERMINAL	BRASS STRIP	6	Ag PLATED OVER Ni PLATED	MODEL: SS-22K26	SCALE : 2:1	DWN.	ZHOUYU	2003-7-5	
3	TERMINAL BASE	PHENOLIC RESIN	1	BLACK			CHK'D	FANGYING	2003-7-5	
2	FRAME	STEEL STRIP	1	Zn PLATED	ALL MATERIALS MUST BE COMPLIANT TO ROHS		APPD.	KANGXINAN	2003-7-5	
1	NOB	PC	1	BLACK						
NO.	PART NAME	MATERIAL	QTY.	FINISHING						